

CM162030 MUK Rev2

**morphy richards**<sup>®</sup>  
smart ideas for your home



## Filter Coffee Maker with Timer and Glass Carafe

 Please read and keep these instructions for future use

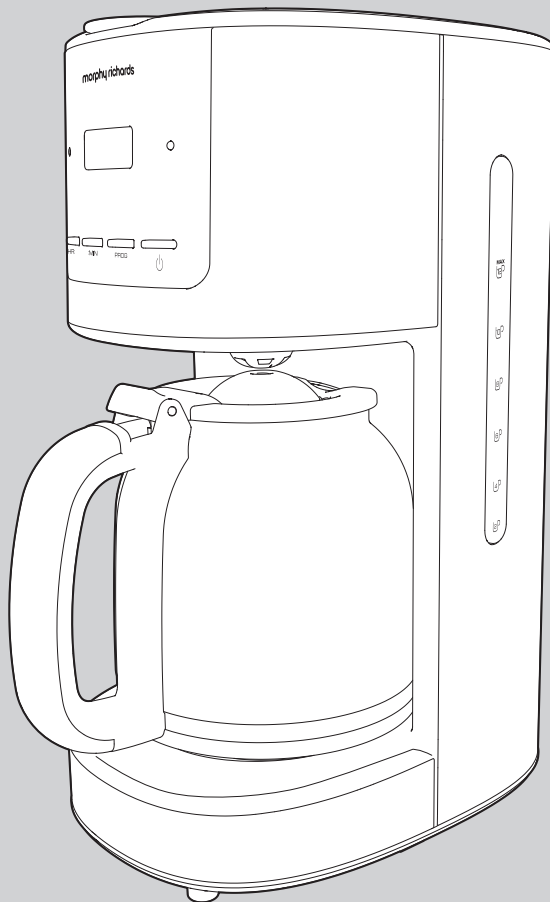

For competitions, product hints and tips  
and more join us at



[www.morphyrichards.co.uk/blog](http://www.morphyrichards.co.uk/blog)



[www.facebook.com/morphyrichardsuk](https://www.facebook.com/morphyrichardsuk)



[@loveyourmorphy](https://twitter.com/loveyourmorphy)

**[www.morphyrichards.com](http://www.morphyrichards.com)**

\* Register online for your 2 year guarantee. See back of this instruction book for details. (UK and Ireland customers only)

## Health and Safety

The use of any electrical appliance requires the following common sense safety rules.

**Please read these instructions carefully before using the product.**

- **WARNING: This appliance incorporates a heating element which is subject to residual heat after use.**
- **WARNING: Misuse of the appliance could cause personal injury.**
- This appliance can be used by children aged from 8 years and above if they have been given supervision or instruction concerning the use of the appliance in a safe way and if they understand the hazards involved. Cleaning and user maintenance shall not be made by children unless they are older than 8 and supervised. Keep the appliance and its cord out of the reach of children aged less than 8 years.
- For care and cleaning, refer to page 6.
- If the mains cable is damaged, it must be replaced by the manufacturer, its service agent or similarly qualified person in order to avoid a hazard.
- Appliances can be used by persons with reduced physical, sensory or mental capabilities or lack of experience and knowledge if they have been given supervision or instruction concerning use of the appliance in a safe way and understand the hazards involved.
- Children shall not play with the appliance.
- This appliance is intended to be used in household and similar applications such as: farm houses, by clients in hotels, motels and other residential type environments, and bed and breakfast type environments. It is not suitable for use in staff kitchen areas in shops, offices and other working environments.

### Location

- Always locate your appliance away from the edge of the worktop.
- Ensure that the appliance is used on a firm, flat surface.
- Do not use the appliance outdoors or near water.
- **WARNING:** Do not place the appliance onto a metal tray or metal surface whilst in use.

### Mains cable

- Do not let the mains cable hang over the edge of the worktop where a child could reach it.
- Do not let the mains cable run across an open space e.g. between a low socket and a table.
- Do not let the mains cable run across a cooker or other hot area which might damage the cable.
- The mains cable should reach from the socket to the base unit without straining the connections.

### Personal safety

- **WARNING:** To protect against fire, electric shock and personal injury do not immerse cord, plug and appliance in water or any other liquid.
- Unplug from the outlet before cleaning.

- Allow to cool before putting on or taking off parts and before cleaning.
  - Do not move the Coffee Maker while switched on.
- ### Other safety considerations
- The use of attachments or tools not recommended or sold by Morphy Richards, may cause fire, electric shock or injury.
  - Do not use the appliance for any use other than its intended purpose.
  - Do not place the appliance on or near a hot gas or electric burner or in a heated oven.
  - **WARNING:** The appliance must not be immersed for cleaning.
  - **CAUTION:** To prevent damage to the appliance, do not use alkaline cleaning agents when cleaning. Use a soft cloth and detergent.

### Electrical requirements

Should the fuse in the mains plug require changing, replace it with a fuse of the same rating as originally fitted.

**WARNING: This appliance must be earthed.**

## Product Overview

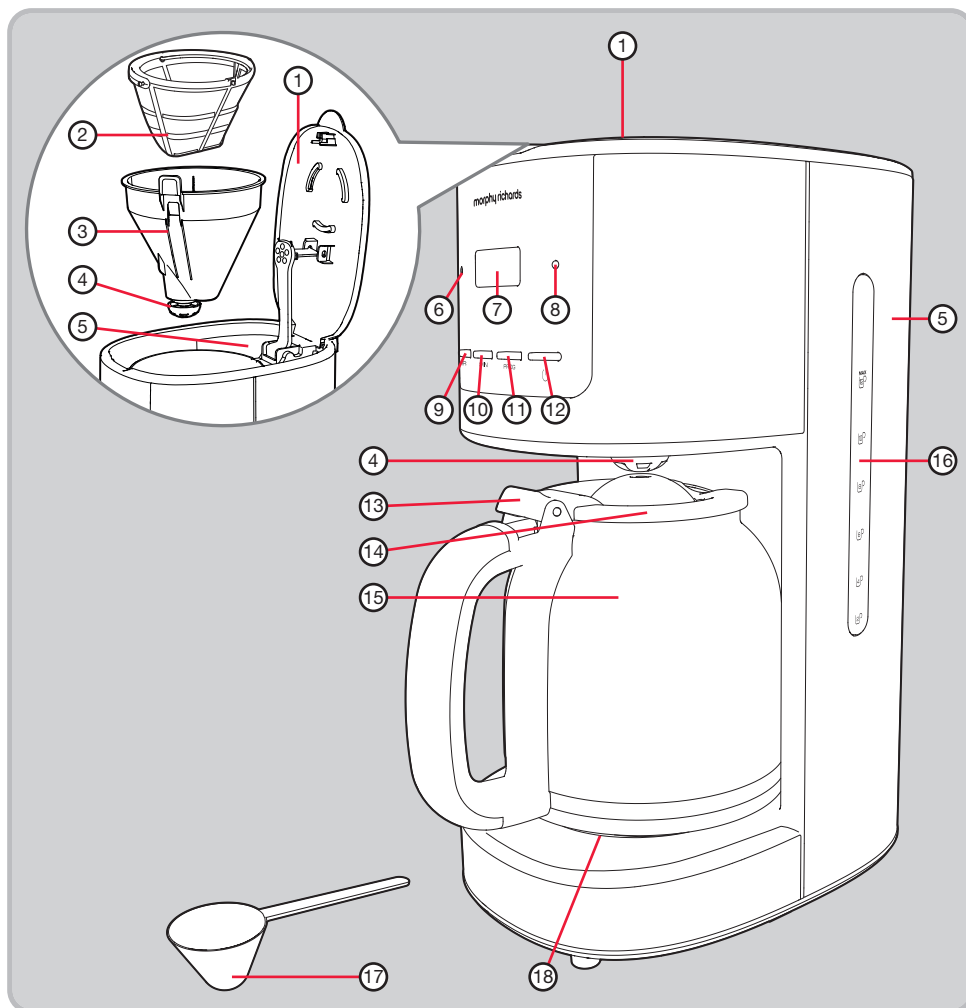

## Features

- |                                |                       |                     |
|--------------------------------|-----------------------|---------------------|
| (1) Lid                        | (7) Display Screen    | (13) Lid Open Lever |
| (2) Removable Permanent Filter | (8) Red Heating Light | (14) Carafe Lid     |
| (3) Removable Filter Holder    | (9) Hour Button       | (15) Glass Carafe   |
| (4) Coffee Dispenser Valve     | (10) Minute Button    | (16) Water Gauge    |
| (5) Water Reservoir            | (11) Auto/Prog Button | (17) Coffee Spoon   |
| (6) Green Programme Light      | (12) On/Off Button    | (18) Hotplate       |

## Before First Use

- Take your Coffee Maker out of the box and remove the packaging.
- Wash the detachable parts of the machine in warm soapy water.
- The first time you use your Coffee Maker, operate the Coffee Maker with water only.

## Setting the Clock

- When the Coffee Maker is plugged in, 12:00 AM will appear on the Display Screen (7).
- To set the time, use the Hour (9) and Minute (10) Buttons. The display is a 12 hour clock.
- When the Coffee Maker is in standby mode, you can use the Hour and Minute Buttons to adjust the clock.

## Using Your Coffee Maker

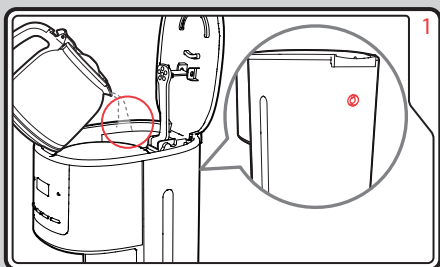

Fill the Water Reservoir (5) with cold water. Do not overfill.

If the Water Reservoir (5) is overfilled, the water will overflow from a hole on the back of the product.

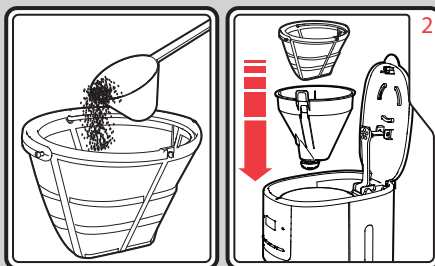

Use the Coffee Spoon (17) to add filter coffee into the Removable Permanent Filter (2). We recommend 7g (one spoon) of coffee per cup, use more ground coffee if you desire a stronger flavour. Place the Filter into the Removable Filter Holder (3) in the Coffee Maker.

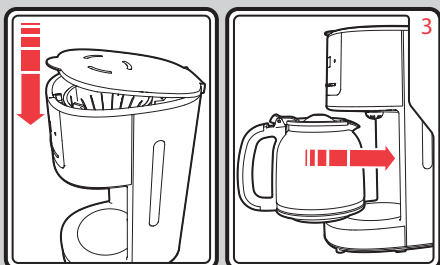

Close the Lid (1) and replace the Glass Carafe (15) into the Coffee Maker.

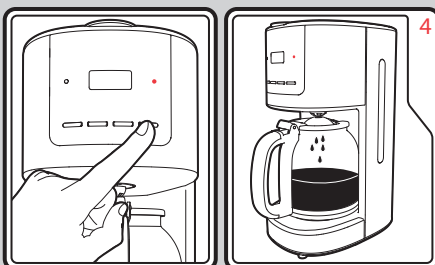

Press the On/Off Button (12) to start the brewing process, the Red Heating Light (8) will illuminate. To stop the brewing process, press the On/Off Button a second time.

Alternatively, not pressing the On/Off Button a second time allows the unit to automatically enter Keep Warm mode for 30 minutes.

## To Pre-set a Brewing Time

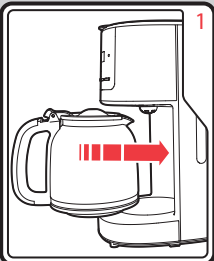
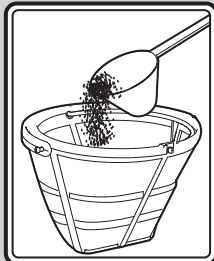

Follow 'Using your Coffee Maker' steps 1-3 on page 4.

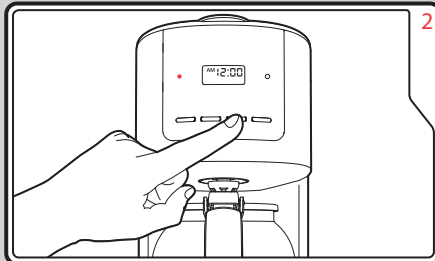

Press the Auto/Prog Button (11) so that the Green Programme Light (6) illuminates and 12:00 AM flashes on the Display Screen (7).

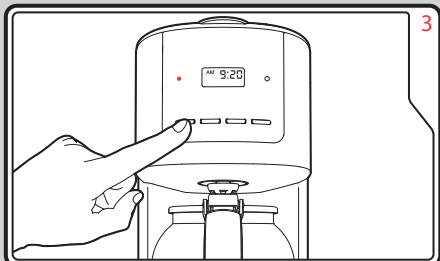

Select the brewing start time using the Hour (9) and Minute (10) Buttons.

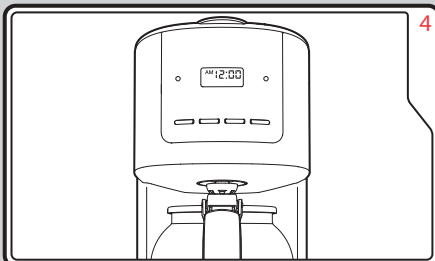

When you have selected the desired time, wait until the time and the Green Programme Light (6) stop flashing. Once set, the Display Screen will return to displaying the current time.

To activate the timer, press and hold the Auto/Prog Button (11) for approximately 5 seconds. The Green Programme Light (6) will illuminate and the programme is set.

## Refilling Your Coffee Maker

- Allow 3 minutes to cool before refilling with cold water.

## Keep Warm

After the brewing cycle has finished, your Coffee Maker will activate the keep warm function which will keep your coffee warm for approximately 30 minutes.

The On/Off Button (12) will remain illuminated, then switch off when the keep warm cycle has finished.

To switch the keep warm mode off press the On/Off Button.

## Cleaning Your Coffee Maker

- Unplug the Coffee Maker and allow to cool.
- Do not immerse the Coffee Maker in liquid.
- Rinse the Water Reservoir (5) occasionally with cold water. Do not use a cloth as any residue or lint may be left behind to clog the Coffee Maker.
- Remove the Permanent Filter (2), discard any used coffee and wash. Extended soaking helps to remove coffee stains from the mesh.
- Wash the Glass Carafe (15), Carafe Lid (14), and Removable Filter Holder (3) in warm soapy water. Rinse and dry all parts thoroughly. Refit the Permanent Filter (2) and Filter Holder.
- Wipe all external surfaces with a damp cloth and dry thoroughly.
- Care must be taken to ensure that the non-drip Coffee Dispenser Valve (4) situated on the bottom of the Removable Filter Holder is not damaged during cleaning.
- Never use harsh or abrasive cleaners.
- NO parts are suitable for cleaning in a dishwasher.

## Descaling

- If you live in a hard water area, we recommend that your Coffee Maker is descaled at regular intervals, e.g. every 1-2 months. In areas of moderately hard water, you should descale every 6 months.
- If the water filters through more slowly than usual, or if water still remains in the reservoir at the end of a cycle, it is a sign that descaling is necessary.
- We recommend you use a proprietary liquid descaler which is especially made for coffee makers and plastic kettles. Follow the instructions on the bottle or sachet, and then operate the Coffee Maker with just water 3 times before making coffee.
- Do not use a kettle descaler unless the packet specifically states it is suitable for Coffee Makers.

Note: The Removable Permanent Filter should not be used during descaling.

## Contact Us

### Helpline

If you are having a problem with your appliance, please call our Helpline, as we are more likely to be able to help than the store you purchased the item from.

Please have the product name, model number and serial number to hand when you call to help us deal with your enquiry quicker.

UK Helpline: **0344 871 0944**

IRE Helpline: **1800 409 119**

Spares: **0344 873 0710**

### Talk To Us

If you have any questions or comments, or want some great tips or recipe ideas to help you get the most out of your products, join us online:

Blog: **[www.homeofthehouseproud.com](http://www.homeofthehouseproud.com)**

Facebook: **[www.facebook.com/morphyrichardsuk](https://www.facebook.com/morphyrichardsuk)**

Twitter: **[www.twitter.com/loveyourmorphy](https://www.twitter.com/loveyourmorphy)**

Website: **[www.morphyrichards.com](http://www.morphyrichards.com)**



CM162030 MUK Rev2 11/19

## Registering Your 2 Year Guarantee

Your standard one year guarantee is extended for an additional 12 months when you register the product within 28 days of purchase with Morphy Richards. If you do not register the product with Morphy Richards within 28 days, your product is guaranteed for 1 year. To validate your 2 year guarantee register with us online at

[www.morphyrichards.co.uk](http://www.morphyrichards.co.uk)

Or call our customer registration line

**UK 0344 871 0242**

**IRE 1800 409 119**

N.B. Each qualifying product needs to be registered with Morphy Richards individually.

Please note that the 2 year guarantee is only available in the UK and Ireland. Please refer to the one year guarantee for more information.

## Your 1 Year Guarantee

It is important to retain the retailer's receipt as proof of purchase. Staple your receipt to this back cover for future reference.

Please quote the following information if the product develops a fault. These numbers can be found on the base of the product.

Model no.

Serial no.

All Morphy Richards products are individually tested before leaving the factory. In the unlikely event of any appliance proving to be faulty within 28 days of purchase, it should be returned to the place of purchase for it to be replaced.

If the fault develops after 28 days and within 12 months of original purchase, you should contact the Helpline number quoting Model number and Serial number on the product, or write to Morphy Richards at the address shown.

You may be asked to return a copy of proof of purchase.

Subject to the exclusions set out below (see Exclusions), the faulty appliance will then be repaired or replaced as appropriate and dispatched usually within 7 working days of receipt.

If, for any reason, this item is replaced or repaired during the 1 year guarantee period, the guarantee on the new item will be calculated from original purchase date. Therefore it is vital to retain your original till receipt or invoice to indicate the date of initial purchase.

To qualify for the 1 year guarantee, the appliance must have been used according to the instructions supplied. For example, crumb trays should have been emptied regularly.

## Exclusions

Morphy Richards shall not be liable to replace or repair the goods under the terms of the guarantee where:

- 1 The fault has been caused or is attributable to accidental use, misuse, negligent use or used contrary to the manufacturer's recommendations or where the fault has been caused by power surges or damage caused in transit.
  - 2 The appliance has been used on a voltage supply other than that stamped on the products.
  - 3 Repairs have been attempted by persons other than our service staff (or authorised dealer).
  - 4 The appliance has been used for hire purposes or non domestic use.
  - 5 The appliance is second hand.
  - 6 Morphy Richards reserves the right not to carry out any type of servicing under the guarantee at its discretion
  - 7 Plastic filters for all Morphy Richards Kettles and Coffee Makers are not covered by the guarantee.
  - 8 Batteries and damage from leakage are not covered by the guarantee.
- This guarantee does not confer any rights other than those expressly set out above and does not cover any claims for consequential loss or damage. This guarantee is offered as an additional benefit and does not affect your statutory rights as a consumer. Morphy Richards products are intended for household use only. See usage limitations within the location safety instructions.

## Disclaimer

Morphy Richards has a policy of continuous improvement in product quality and design. The company, therefore reserves the right to change the specification of its models at any time.



For electrical products sold within the European Community. At the end of the electrical products useful life, it should not be disposed of with household waste.

Please recycle where facilities exist. Check with your Local Authority or retailer for recycling advice in your country

**IF YOU ARE HAVING A PROBLEM  
WITH ONE OF OUR PRODUCTS,  
CALL OUR HELPLINE:**

**UK: 0344 871 0944  
EIRE: 1800 409 119  
SPARES: 0344 873 0710**

**morphyrichards**

The After Sales Division  
Morphy Richards Ltd  
Mexborough, South Yorkshire,  
England, S64 8AJ

Helplines (office hours)  
UK 0344 871 0944  
Spare Parts 0344 873 0710  
Republic of Ireland 1800 409 119  
[www.morphyrichards.com](http://www.morphyrichards.com)

