



Ace



PRO SALON HOOD DRYER



complies with
INTERNATIONAL
IEC60335
SAFETY SPECIFICATIONS



1000 W

1 YEAR
WARRANTY

Model: SHD14BLA, SHD14GRA,
SHD14ORA, SHD14RDA,
SHD14WHA



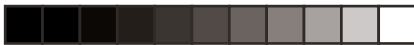

Dear customer,

Thank you for choosing to purchase a ACE brand product. Thanks to its technology, design and operation and the fact that it exceeds the strictest quality standards, a fully satisfactory use and long product life can be assured.

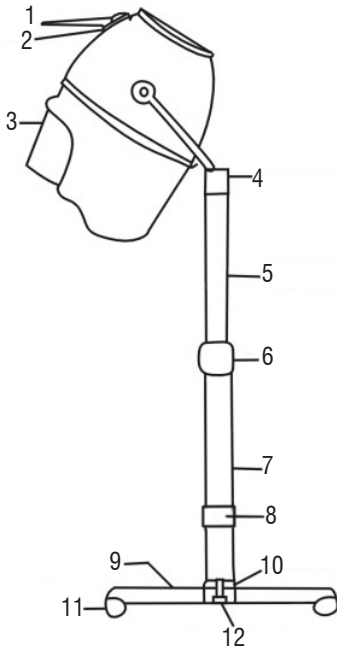

1. Parts description

- 1- Timer and heat settings
- 2- On/Off switch
- 3- Visor
- 4- Hood sliding cap
- 5- Top pole
- 6- Tension adjustment ring
- 7- Base pole
- 8- Connection ring
- 9- Base legs
- 10- Base center piece
- 11- Base wheels
- 12- Bolt washer

2. Safety advice and warnings!

Read these instructions carefully before switching on the appliance and keep them for future reference. Fail-

ure to follow and observe these instructions could lead to an accident. Clean all the parts of the product that will be in contact with face, as indicated in the cleaning section, before use.

2.1. Use or working environment:

- 2.1.1. Keep the working area clean and well lit. Cluttered and dark areas invite accidents.
- 2.1.2. Use the appliance in a well ventilated area.
- 2.1.3. Do not place the appliance on hot surfaces, such as cooking plates, gas burners, ovens or similar items.
- 2.1.4. Keep children and bystanders away when using this appliance.
- 2.1.5. Place the appliance on a horizontal, flat, stable surface away from other heat sources.
- 2.1.6. Do not use the appliance in association with a programmer, timer or other device that automatically switches it on.
- 2.1.7. Do not use the appliance if the cable or plug is damaged.
- 2.1.8. Ensure that the voltage indicated on the rating label matches the mains power supply voltage before plugging in the appliance.
- 2.1.9. Connect the appliance to the mains power supply with an earth socket withstanding a minimum of 10 amperes.
- 2.1.10. The appliance's plug must fit into the mains power supply socket properly. Do not alter the plug.
- 2.1.11. If using a multi plug check ratings carefully as the current used by several appliances could easily exceed the rating of the multi plug.
- 2.1.12. If any of the appliance casings breaks, immediately disconnect the appliance from the mains power supply to prevent the possibility of an electric shock.
- 2.1.13. Do not use the appliance if it has fallen on the floor or if there are visible signs of damage.
- 2.1.14. Do not force the power cord. Never use the power cord to lift up, carry or unplug the appliance.
- 2.1.15. Do not wrap the power cord around the appliance.
- 2.1.16. Do not clip or crease the power cord.
- 2.1.17. Do not allow the power cord to hang or to come into contact with the surfaces.
- 2.1.18. Check the state of the power cord. Damaged or tangled cables increase the risk of electric shock.
- 2.1.19. Power cord should be regularly examined for signs of damage, and if the cord is damaged, the appliance must not be used.
- 2.1.20. Do not touch the plug with wet hands.





2.2. Personal safety:

2.2.1. CAUTION: Do not leave the appliance unattended during use as there is a risk of an accident.

2.2.2. This appliance is only for domestic use, not for industrial or professional use. It is not intended to be used by guests in hospitality environments such as bed and breakfast, hotels, motels, and other types of residential environments, even in farm houses, offices and other work environments.

2.2.3. This appliance is not intended for use by persons (including children) with reduced physical, sensory or mental capabilities, or lack of experience and knowledge, unless they have been given supervision or instruction concerning use of the appliance by a person responsible for their safety.

2.2.4. This appliance is not a toy. Children should be supervised to ensure that they do not play with the appliance.

2.3. Use and care:

2.3.1. Fully unroll the appliance's power cable before each use.

2.3.2. Do not use the appliance if the parts or accessories are not properly fitted.

2.3.3. Unplug the appliance from the mains power supply when not in use and before undertaking any cleaning task.

2.3.4. This appliance should be stored out of reach of children.

2.3.5. Do not store the appliance if it is still on/hot.

2.3.6. Never leave the appliance unattended when in use and keep out of the reach of children.

2.3.7. If, for some reason, the appliance were to catch fire, disconnect the appliance from the mains power supply and DO NOT USE WATER TO PUT THE FIRE OUT.

2.4. Service:

2.4.1. Make sure that the appliance is serviced only by suitably qualified technician, and that only original spare parts or accessories are used to replace existing parts/accessories.

2.4.2. If the power cord is damaged, the manufacturer or its service agent or a similarly qualified person must replace it in order to avoid a hazard.

2.4.3. Any misuse or failure to follow the instructions for use renders the guarantee and the manufacturer's liability null and void.

3. Instructions for use

3.1. Before use:

3.1.1. Remove the appliance's protective film (if applicable).

3.1.2. Before using the product for the first time, clean the appliance in the manner described in the cleaning section.

3.2. Use and care:

3.2.1. Assembly instructions

1. Press each wheel securely into each of the base legs.
2. Connect each base leg into base centre piece.
3. Secure base pole into base centre piece with washer and bolt provided.
4. Slide top pole into connection cap and tighten at the correct height.
5. Gently slide helmet hood sliding cap onto top of top pole.
6. Make sure the power cord is secured in the clip-on cord grip on base pole.
7. The appliance is ready to use once plugged into a power supply 230V.

3.2.2. Operating instructions

After washing, towel drying and setting your hair, insert the plug into the wall socket Press on/off switch to "ON" position. Turn the time switch clockwise to set the time (between 0 and 60 minutes). Adjust the temperature control between 0 degrees centigrade (COLD) to 60 degrees centigrade (HOT). Drying process will start and a bell will ring when the time selected has is completed. Switch off the appliance after use and remove the plug from the wall socket. Store in a dry, dust free place, out of reach of children.

3.3 Once you have finished using the appliance:

3.3.1. Allow appliance to cool down.

3.3.2. Unplug the appliance from the mains power supply.

3.3.3. Clean the appliance as described in the cleaning section.

4. Cleaning and maintenance:





- 4.1. Disconnect the appliance from the mains and allow it to cool completely before undertaking any cleaning task.
- 4.2. Clean the appliance with a damp cloth with a few drops of washing-up liquid and then dry. **CAUTION!** Do not immerse electrical parts of the pan in any liquid.
- 4.3. Do not use solvents, or products with an acid or base pH such as bleach, or abrasive products, for cleaning the appliance.
- 4.4. Never submerge the appliance in water or any other liquid or place it under running water.

5. Anomalies and repair

- 5.1. Take the appliance to an authorised support centre if product is damaged or other problems arise.
- 5.2. If the connection to the mains has been damaged, it must be replaced and you should proceed as you would in the case of damage.





Ace

Ace guarantees that this product has been thoroughly inspected and tested before being dispatched and is free from mechanical and electrical defects and complies with the applicable safety standards. However, should defects due to faulty material or workmanship develop, under normal domestic use, within 6 months from the date of purchase please return the product to the store from where it was purchased for a full refund or replacement.

Extended 12 Month Limited Warranty

Ace offer an extended 12 month limited warranty from the date of purchase to offer the consumer peace of mind on their purchase. Should defects due to faulty material or workmanship develop, under normal domestic use, within 12 months from the date of purchase, please return the product to the store from where it was purchased for replacement.

The following conditions apply:

- 1) Please ensure you retain your receipt as this must be presented when making a claim under the terms of the warranty. It is impossible to determine the warranty period without proof of purchase, so please keep this in a safe place.
- 2) If a refund or exchange is required the product must be complete with all accessories, parts and packaging. Missing parts will render the warranty void.
- 3) Upon receipt of your appliance check it for any transport damage to ensure it is safe for use. Return it to the store as soon as possible for exchange if damaged. The warranty is void if products are damaged after use, so please do not use the damaged product.
- 4) Your product is designed for normal domestic household use. Failure to read and comply with the instructions for use, cleaning and maintenance will render your warranty void, so please read these instructions carefully to ensure your safety, and get the most effective use from the product. (e.g. lime scale; water deposits; and/or insect infestation)
- 5) Any abuse, negligent, improper or accidental use or care will render the warranty void and Creative Housewares (Pty) Ltd will not be liable for any loss or damage.
- 6) Any attempted repair, or replacement of unauthorised parts will render the warranty void, so please contact an authorised service centre or agent for any service or repair requirements.

Before returning your product, check for the following:

- 1) Your household mains supply socket is working and switched on.
- 2) The mains supply circuit is not overloaded (White trip switch on your DB board is off).
- 3) You have read the trouble shooting guide in your Instructions for Use.
- 4) All accessories and parts are present.

If service or repair becomes necessary outside the warranty period, this service is still available however all transport/postage, spares and labour costs will be paid by the consumer. All chargeable repairs will require the consumers' approval in writing once the quote is accepted. Once the go-ahead has been received Ace will undertake to conduct the repair within a reasonable time and maintain the condition of the product as received.

All repairs carry a 3 month warranty. Ace will attempt to conduct repairs within reasonable industry standards but cannot be held responsible or liable for any circumstances not under their direct control.

National Service Centre: 086 111 5006

e-mail: help@creativehousewares.co.za

creative housewares

web: www.creativehousewares.co.za

Cape Town

20 Tekstiel Street, Parow, Cape Town, 7493, South Africa • P.O. Box 6156 Parow East, 7501, South Africa
Tel: +27 21 931 8117
Fax: +27 21 931 4058

Durban

35 Adrain Road, Windermere, Durban, South Africa, 4001
Tel: +27 31 303 3465
Fax: +27 31 303 8259

Johannesburg

Unit 25 & 26 San Croy Officepark, Die Agora Road, Croydon, 1619
Tel: +27 11 392 5652
Fax: +27 11 392 1694

1 year warranty





Ace

creative housewares

🏠 20 Tekstiel Street, Parow, Cape Town, 7493, South Africa

✉ P.O. Box 6156 Parow East, 7501, South Africa

☎ +27 21 931 8117 📠 +27 21 931 4058

Service Centre Helpline: 086 111 5006

🌐 www.creativehousewares.co.za

